

THIS DOCUMENT CONTAINS DATA PROPRIETARY TO PROJECTS UNLIMITED, INC. ANY USE OR REPRODUCTION, IN ANY FORM, WITHOUT PRIOR WRITTEN PERMISSION OF PROJECTS UNLIMITED, INC. IS PROHIBITED.  
© 2003, Projects Unlimited Inc.

### SPECIFICATIONS

| PARAMETERS                                      | VALUES        | UNITS |
|---|---------------|-------|
| RATED INPUT POWER                               | 10            | W     |
| MAX INPUT POWER                                 | 15            | W     |
| IMPEDANCE                                       | 8±15%         | OHM   |
| OUTPUT SPL @ 1W/1W<br>(AT 0.8, 1, 1.2, 1.5 KHz) | 88±3          | dBA   |
| DISTORTION                                      | 7%            | -     |
| RESONANT FREQUENCY                              | 120±20%       | Hz    |
| FREQUENCY RANGE                                 | 120 ~ 17,000  | Hz    |
| HOUSING MATERIAL                                | METAL         | -     |
| CONE MATERIAL                                   | TREATED PAPER | -     |
| MAGNET MATERIAL                                 | FERRITE       | -     |
| OPERATING TEMPERATURE                           | -10 ~ +85     | °C    |
| WEIGHT  | 275           | grams |

| REVISIONS |                           |         |          |
|-----------|---------------------------|---------|----------|
| LTR       | DESCRIPTION               | DATE    | APPROVED |
| -         | RELEASED FROM ENGINEERING | 3/31/06 |          |

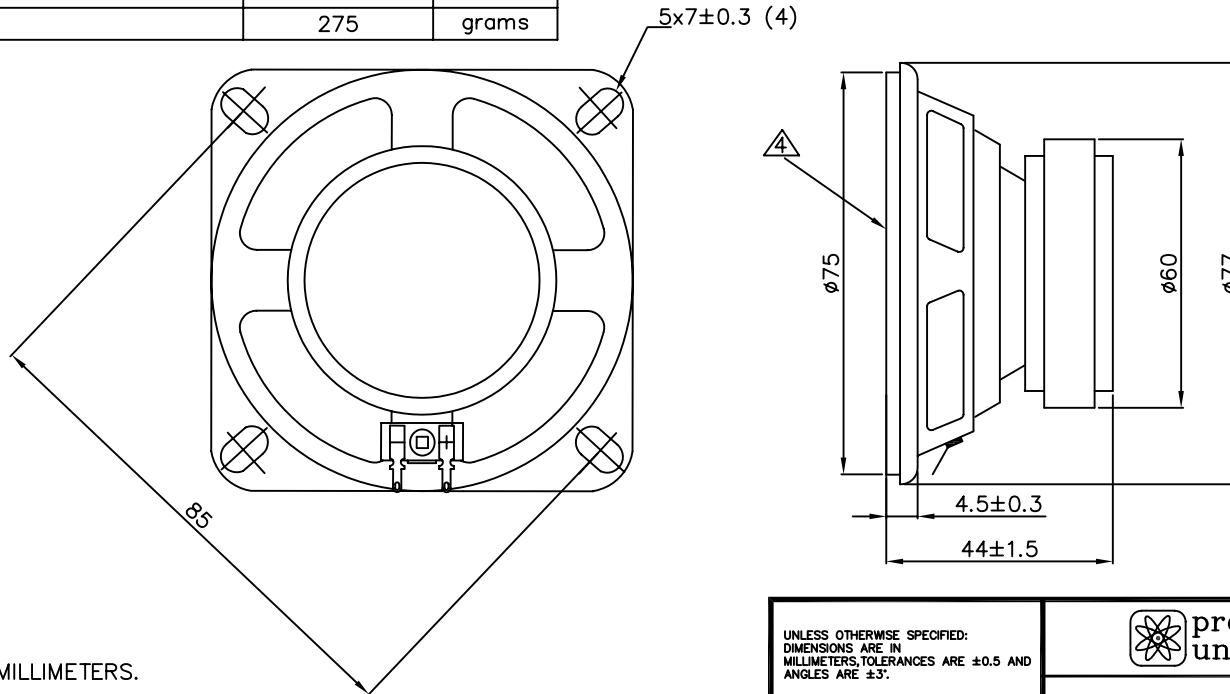

**NOTES:**

1. ALL DIMENSIONS ARE IN MILLIMETERS.
2. SPECIFICATION SUBJECT TO CHANGE OR WITHDRAWAL WITHOUT NOTICE.
3. THIS PART IS RoHS 2002/95/EC COMPLIANT.
4. CONE HAS BEEN TREATED FOR WATER RESISTANCE.

FILE NAME  
AS07708PS-3-WR-R.DWG

| UNLESS OTHERWISE SPECIFIED:<br>DIMENSIONS ARE IN MILLIMETERS, TOLERANCES ARE ±0.5 AND ANGLES ARE ±3°.  |      |  <b>projects® unlimited</b><br>Dayton, Ohio |                            |                   |      |                     |      |                      |      |  |  |
|--|------|--|----------------------------|-------------------|------|---------------------|------|----------------------|------|--|--|
| <table border="1"> <thead> <tr> <th>APPROVALS</th> <th>DATE</th> </tr> </thead> <tbody> <tr> <td>DRAWN <i>B.R.</i></td> <td>3/06</td> </tr> <tr> <td>CHECKED <i>B.R.</i></td> <td>3/06</td> </tr> <tr> <td>APPROVED <i>E.P.</i></td> <td>3/06</td> </tr> </tbody> </table> |      | APPROVALS  | DATE                       | DRAWN <i>B.R.</i> | 3/06 | CHECKED <i>B.R.</i> | 3/06 | APPROVED <i>E.P.</i> | 3/06 | <p align="center"><b>SPEAKER</b><br/>AS07708PS-3-WR-R</p> <p align="center">DRAWING NO.<br/>AS07708PS-3-WR-R</p> |  |
| APPROVALS  | DATE |  |                            |                   |      |                     |      |                      |      |  |  |
| DRAWN <i>B.R.</i>  | 3/06 |  |                            |                   |      |                     |      |                      |      |  |  |
| CHECKED <i>B.R.</i>  | 3/06 |  |                            |                   |      |                     |      |                      |      |  |  |
| APPROVED <i>E.P.</i>   | 3/06 |  |                            |                   |      |                     |      |                      |      |  |  |
| DO NOT SCALE DRAWING   |      | SIZE<br>A  | SCALE: N.T.S. SHEET 1 OF 1 |                   |      |                     |      |                      |      |  |  |